

# STORAGE DESIGN

## 2.2.1 General Storage Concepts

### 2.2.1.1 Introduction

This section provides general guidance on stormwater runoff storage for meeting stormwater management control requirements (i.e., water quality treatment, downstream channel protection, overbank flood protection, and extreme flood protection).

Storage of stormwater runoff within a stormwater management system is essential to providing the extended detention of flows for water quality treatment and downstream channel protection, as well as for peak flow attenuation of larger flows for overbank and extreme flood protection. Runoff storage can be provided within an on-site system through the use of structural stormwater controls and/or nonstructural features and landscaped areas. Figure 2.2.1-1 illustrates various storage facilities that can be considered for a development site.

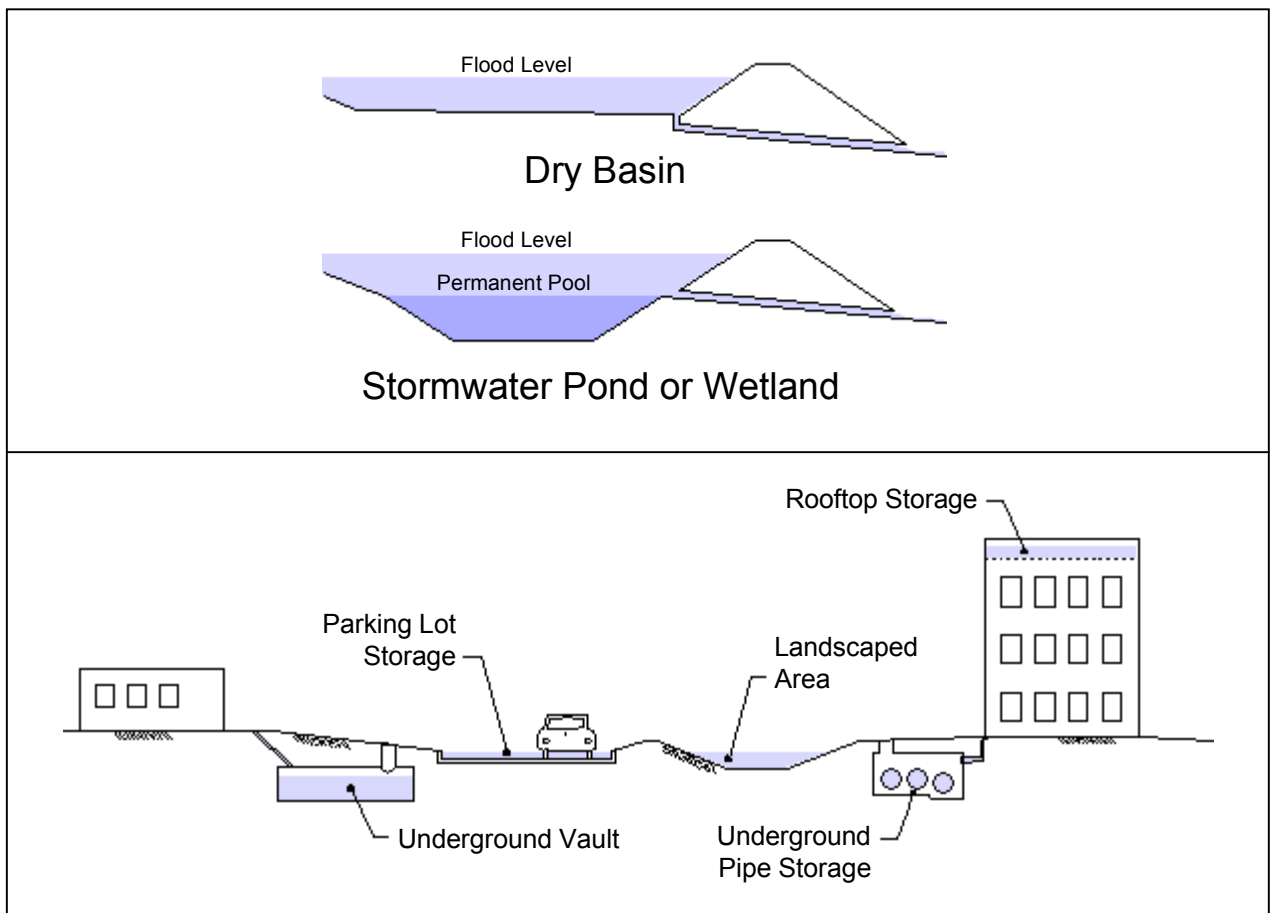

Figure 2.2.1-1 Examples of Typical Stormwater Storage Facilities

Stormwater *detention* is used to reduce the peak discharge and detain runoff for a specified short period of time. Detention volumes are designed to completely drain after the design storm has passed. Detention is used to meet overbank flood protection criteria, and extreme flood criteria where required.

*Extended detention* (ED) is used to drain a runoff volume over a specified period of time, typically 24 hours, and is used to meet channel protection criteria. Some structural control designs (wet ED pond, micropool ED pond, and shallow ED marsh) also include extended detention storage of a portion of the water quality volume.

*Retention* facilities are designed to contain a permanent pool of water, such as stormwater ponds and wetlands, that is used for water quality treatment.

Storage facilities are often classified on the basis of their location and size. *On-site* storage is constructed on individual development sites. *Regional* storage facilities are constructed at the lower end of a subwatershed and are designed to manage stormwater runoff from multiple projects and/or properties. A discussion of regional stormwater controls is found in Section 3.1.

Storage can also be categorized as *on-line* or *off-line*. On-line storage uses a structural control facility that intercepts flows directly within a conveyance system or stream. Off-line storage is a separate storage facility to which flow is diverted from the conveyance system. Figure 2.2.1-2 illustrates on-line versus off-line storage.

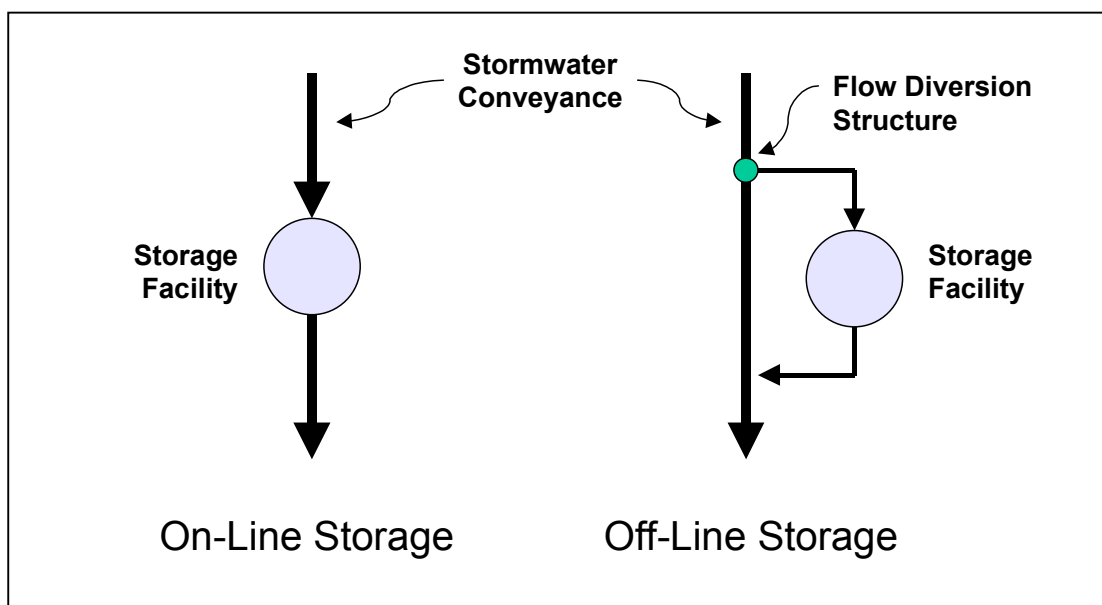

Figure 2.2.1-2 On-Line versus Off-Line Storage

### 2.2.1.2 Storage Classification

Stormwater storage(s) can be classified as either detention, extended detention or retention. Some facilities include one or more types of storage.

### 2.2.1.3 Stage-Storage Relationship

A stage-storage curve defines the relationship between the depth of water and storage volume in a storage facility (see Figure 2.2.1-3). The volume of storage can be calculated by using simple geometric formulas expressed as a function of depth.

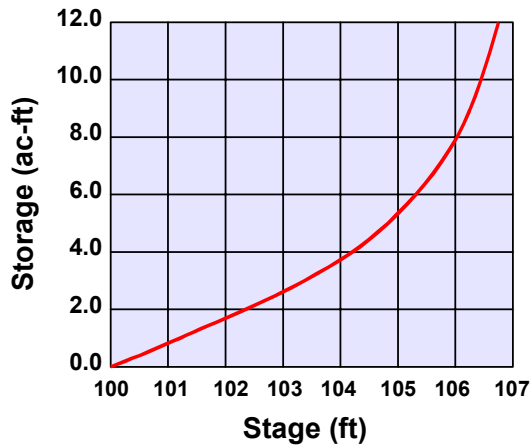
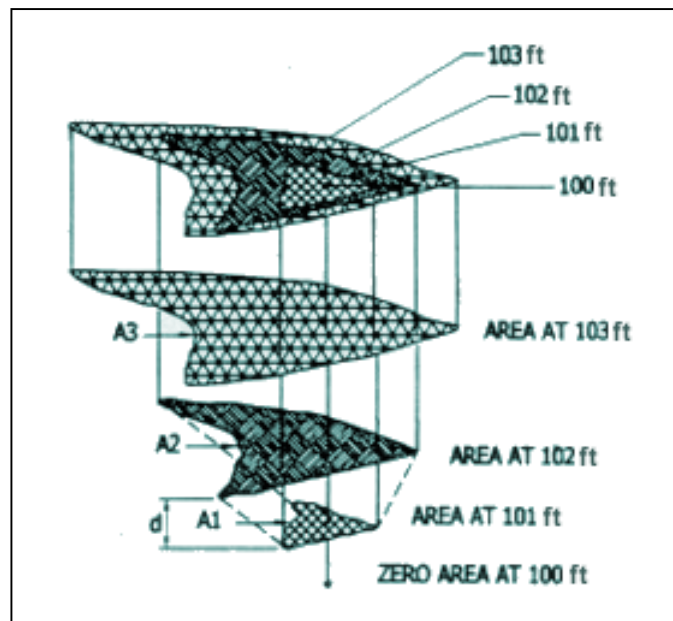

**Figure 2.2.1-3 Stage-Storage Curve**

The storage volume for natural basins may be developed using a topographic map and the double-end area, frustum of a pyramid, prismatic or circular conic section formulas.

The double-end area formula (see Figure 2.2.1-4) is expressed as:

$$V_{1,2} = [(A_1 + A_2)/2]d \tag{2.2.1}$$



**Figure 2.2.1-4 Double-End Area Method**

Where:  $V_{1,2}$  = storage volume (ft<sup>3</sup>) between elevations 1 and 2  
 $A_1$  = surface area at elevation 1 (ft<sup>2</sup>)  
 $A_2$  = surface area at elevation 2 (ft<sup>2</sup>)  
 $d$  = change in elevation between points 1 and 2 (ft)

The frustum of a pyramid formula is expressed as:

$$V = d/3 [A_1 + (A_1 \times A_2)^{0.5} + A_2]/3 \tag{2.2.2}$$

Where:  $V$  = volume of frustum of a pyramid (ft<sup>3</sup>)  
 $d$  = change in elevation between points 1 and 2 (ft)

- A<sub>1</sub> = surface area at elevation 1 (ft<sup>2</sup>)
- A<sub>2</sub> = surface area at elevation 2 (ft<sup>2</sup>)

The prismoidal formula for trapezoidal basins is expressed as:

$$V = LWD + (L + W) ZD^2 + 4/3 Z^2 D^3 \tag{2.2.3}$$

- Where:
- V = volume of trapezoidal basin (ft<sup>3</sup>)
  - L = length of basin at base (ft)
  - W = width of basin at base (ft)
  - D = depth of basin (ft)
  - Z = side slope factor, ratio of horizontal to vertical

The circular conic section formula is:

$$V = 1.047 D (R_1^2 + R_2^2 + R_1R_2) \tag{2.2.4}$$

$$V = 1.047 D (3 R_1^2 + 3ZDR_1 + Z_2D^2) \tag{2.2.5}$$

- Where:
- R<sub>1</sub>, R<sub>2</sub> = bottom and surface radii of the conic section (ft)
  - D = depth of basin (ft)
  - Z = side slope factor, ratio of horizontal to vertical

#### 2.2.1.4 Stage-Discharge Relationship

A stage-discharge curve defines the relationship between the depth of water and the discharge or outflow from a storage facility (see Figure 2.2.1-5). A typical storage facility has two outlets or spillways: a principal outlet and a secondary (or emergency) outlet. The principal outlet is usually designed with a capacity sufficient to convey the design flows without allowing flow to enter the emergency spillway. A pipe culvert, weir, or other appropriate outlet can be used for the principal spillway or outlet.

The emergency spillway is sized to provide a bypass for floodwater during a flood that exceeds the design capacity of the principal outlet. This spillway should be designed taking into account the potential threat to downstream areas if the storage facility were to fail. The stage-discharge curve should take into account the discharge characteristics of both the principal spillway and the emergency spillway. For more details, see Section 2.3, *Outlet Structures*.

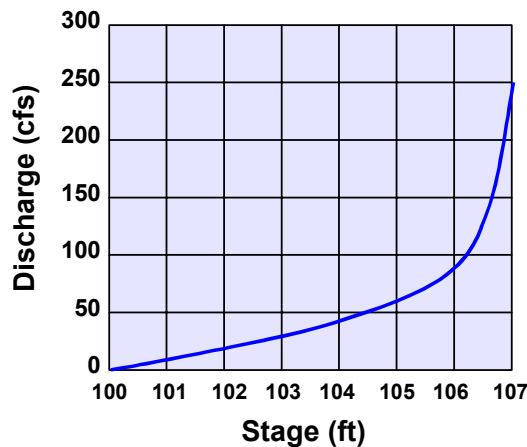

Figure 2.2.1-5 Stage-Discharge Curve

## 2.2.2 Symbols and Definitions

To provide consistency within this section as well as throughout this Manual, the symbols listed in Table 2.2.2-1 will be used. These symbols were selected because of their wide use in technical publications. In some cases, the same symbol is used in existing publications for more than one definition. Where this occurs in this section, the symbol will be defined where it occurs in the text or equations.

<b><u>Symbol</u></b>	<b><u>Definition</u></b>	<b><u>Units</u></b>
A	Cross sectional or surface area	ft <sup>2</sup>
A <sub>m</sub>	Drainage area	mi <sup>2</sup>
C	Weir coefficient	-
d	Change in elevation	ft
D	Depth of basin or diameter of pipe	ft
t	Routing time period	sec
g	Acceleration due to gravity	ft/s <sup>2</sup>
H	Head on structure	ft
H <sub>c</sub>	Height of weir crest above channel bottom	ft
K	Coefficient	-
I	Inflow rate	cfs
L	Length	ft
Q,q	Peak inflow or outflow rate	cfs, in
R	Surface Radii	ft
S, V <sub>s</sub>	Storage volume	ft <sup>3</sup>
t <sub>b</sub>	Time base on hydrograph	hrs
T <sub>i</sub>	Duration of basin inflow	hrs
t <sub>p</sub>	Time to peak	hrs
V <sub>s</sub> , S	Storage volume	ft <sup>3</sup> , in, acre-ft
V <sub>r</sub>	Volume of runoff	ft <sup>3</sup> , in, acre-ft
W	Width of basin	ft
Z	Side slope factor	-

## 2.2.3 General Storage Design Procedures

### 2.2.3.1 Introduction

This section discusses the general design procedures for designing storage to provide standard detention of stormwater runoff for overbank and extreme flood protection ( $Q_{p25}$  and  $Q_f$ ).

The design procedures for all structural control storage facilities are the same whether or not they include a permanent pool of water. In the latter case, the permanent pool elevation is taken as the "bottom" of storage and is treated as if it were a solid basin bottom for routing purposes.

It should be noted that the location of structural stormwater controls is very important as it relates to the effectiveness of these facilities to control downstream impacts. In addition, multiple storage facilities located in the same drainage basin will affect the timing of the runoff through the conveyance system, which could decrease or increase flood peaks in different downstream locations. Therefore, a downstream peak flow analysis should be performed as part of the storage facility design process (see subsection 2.1.9).

---

In multi-purpose multi-stage facilities such as stormwater ponds, the design of storage must be integrated with the overall design for water quality treatment objectives. See Chapter 3 for further guidance and criteria for the design of structural stormwater controls.

### 2.2.3.2 Data Needs

The following data are needed for storage design and routing calculations:

- Inflow hydrograph for all selected design storms
- Stage-storage curve for proposed storage facility
- Stage-discharge curve for all outlet control structures

### 2.2.3.3 Design Procedure

A general procedure for using the above data in the design of storage facilities is presented below.

- (Step 1) Compute inflow hydrograph for runoff from the 25- ( $Q_{p25}$ ), and 100-year ( $Q_f$ ) design storms using the hydrologic methods outlined in Section 2.1. Both existing- and post-development hydrographs are required for 25-year design storm.
- (Step 2) Perform preliminary calculations to evaluate detention storage requirements for the hydrographs from Step 1 (see subsection 2.2.4).
- (Step 3) Determine the physical dimensions necessary to hold the estimated volume from Step 2, including freeboard. The maximum storage requirement calculated from Step 2 should be used. From the selected shape determine the maximum depth in the pond.
- (Step 4) Select the type of outlet and size the outlet structure. The estimated peak stage will occur for the estimated volume from Step 2. The outlet structure should be sized to convey the allowable discharge at this stage.
- (Step 5) Perform routing calculations using inflow hydrographs from Step 1 to check the preliminary design using a storage routing computer model. If the routed post-development peak discharges from the 25-year design storm exceed the existing-development peak discharges, then revise the available storage volume, outlet device, etc., and return to Step 3.
- (Step 6) Perform routing calculations using the 100-year hydrograph to determine if any increases in downstream flows from this hydrograph will cause damages and/or drainage and flooding problems. If problems will be created (e.g., flooding of habitable dwellings, property damage, or public access and/or utility interruption) then the storage facility must be designed to control the increased flows from the 100-year storm. If not then consider emergency overflow from runoff due to the 100-year (or larger) design storm and established freeboard requirements.
- (Step 7) Evaluate the downstream effects of detention outflows for the 25- and 100-year storms to ensure that the routed hydrograph does not cause downstream flooding problems. The exit hydrograph from the storage facility should be routed through the downstream channel system until a confluence point is reached where the drainage area being analyzed represents 10% of the total drainage area (see subsection 2.1.9).
- (Step 8) Evaluate the control structure outlet velocity and provide channel and bank stabilization if the velocity will cause erosion problems downstream.

Routing of hydrographs through storage facilities is critical to the proper design of these facilities. Although storage design procedures using inflow/outflow analysis without routing have been

developed, their use in designing detention facilities has not produced acceptable results in many areas of the country, including Georgia.

Although hand calculation procedures are available for routing hydrographs through storage facilities, they are very time consuming, especially when several different designs are evaluated. Many standard hydrology and hydraulics textbooks give examples of hand-routing techniques. For this Manual, it assumed that designers will be using one of the many computer programs available for storage routing and thus other procedures and example applications will not be given here.

## 2.2.4 Preliminary Detention Calculations

### 2.2.4.1 Introduction

Procedures for preliminary detention calculations are included here to provide a simple method that can be used to estimate storage needs and also provide a quick check on the results of using different computer programs. Standard routing should be used for actual (final) storage facility calculations and design.

### 2.2.4.2 Storage Volume

For small drainage areas, a preliminary estimate of the storage volume required for peak flow attenuation may be obtained from a simplified design procedure that replaces the actual inflow and outflow hydrographs with the standard triangular shapes shown in Figure 2.2.4-1.

The required storage volume may be estimated from the area above the outflow hydrograph and inside the inflow hydrograph, expressed as:

$$V_s = 0.5T_i(Q_i - Q_o) \quad (2.2.6)$$

Where:  $V_s$  = storage volume estimate (ft<sup>3</sup>)  
 $Q_i$  = peak inflow rate (cfs)  
 $Q_o$  = peak outflow rate (cfs)  
 $T_i$  = duration of basin inflow (s)

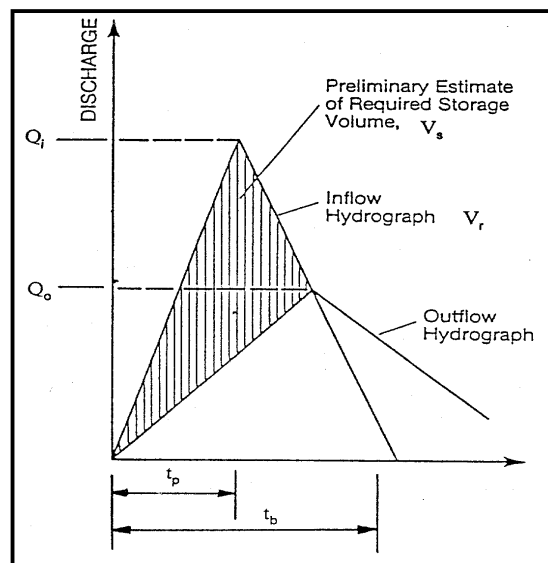

Figure 2.2.4-1 Triangular-Shaped Hydrographs  
 (For Preliminary Estimate of Required Storage Volume)

---

### 2.2.4.3 Alternative Method

An alternative preliminary estimate of the storage volume required for a specified peak flow reduction can be obtained by the following regression equation procedure (Wycoff and Singh, 1976).

(Step 1) Determine input data, including the allowable peak outflow rate,  $Q_o$ , the peak flow rate of the inflow hydrograph,  $Q_i$ , the time base of the inflow hydrograph,  $t_b$ , and the time to peak of the inflow hydrograph,  $t_p$ .

(Step 2) Calculate a preliminary estimate of the ratio  $V_s/V_r$  using the input data from Step 1 and the following equation:

$$\frac{V_s}{V_r} = \frac{1.291 \left( 1 - \frac{Q_o}{Q_i} \right)^{0.753}}{\left( \frac{t_p}{t_b} \right)^{0.411}} \quad (2.2.7)$$

Where:  $V_s$  = volume of storage (in)  
 $V_r$  = volume of runoff (in)  
 $Q_o$  = outflow peak flow (cfs)  
 $Q_i$  = inflow peak flow (cfs)  
 $t_b$  = time base of the inflow hydrograph (hr) [Determined as the time from the beginning of rise to a point on the recession limb where the flow is 5% of the peak]  
 $t_p$  = time to peak of the inflow hydrograph (hr)

(Step 3) Multiply the volume of runoff,  $V_r$ , times the ratio  $V_s/V_r$ , calculated in Step 2 to obtain the estimated storage volume  $V_s$ .

### 2.2.4.4 Peak Flow Reduction

A preliminary estimate of the potential peak flow reduction for a selected storage volume can be obtained by the following procedure.

(Step 1) Determine volume of runoff,  $V_r$ , peak flow rate of the inflow hydrograph,  $Q_i$ , time base of the inflow hydrograph,  $t_b$ , time to peak of the inflow hydrograph,  $t_p$ , and storage volume  $V_s$ .

(Step 2) Calculate a preliminary estimate of the potential peak flow reduction for the selected storage volume using the following equation (Wycoff and Singh, 1976):

$$Q_o/Q_i = 1 - 0.712(V_s/V_r)^{1.328} (t_b/t_p)^{0.546} \quad (2.2.8)$$

Where:  $Q_o$ = outflow peak flow (cfs)  
 $Q_i$ = inflow peak flow (cfs)  
 $V_s$ = volume of storage (in)  
 $V_r$ = volume of runoff (in)  
 $t_b$ = time base of the inflow hydrograph (hr) [Determined as the time from the beginning of rise to a point on the recession limb where the flow is 5 percent of the peak]  
 $t_p$ = time to peak of the inflow hydrograph (hr)

(Step 3) Multiply the peak flow rate of the inflow hydrograph,  $Q_i$ , times the potential peak flow reduction calculated from Step 2 to obtain the estimated peak outflow rate,  $Q_o$ , for the selected storage volume.

---

## 2.2.5 Channel Protection Volume Estimation

### 2.2.5.1 Introduction

The Simplified SCS Peak Runoff Rate Estimation approach (see subsection 2.1.5.7) can be used for estimation of the Channel Protection Volume ( $CP_v$ ) for storage facility design.

This method should not be used for standard detention design calculations. See either subsection 2.2.4 or the modified rational method in subsection 2.2.6 for preliminary detention calculations without formal routing.

### 2.2.5.2 Basic Approach

For  $CP_v$  estimation, using Figures 2.1.5-6 and 2.1.5-7 in Section 2.1, the unit peak discharge ( $q_U$ ) can be determined based on  $I_a/P$  and time of concentration ( $t_c$ ). Knowing  $q_U$  and  $T$  (extended detention time, typically 24 hours), the  $q_o/q_i$  ratio (peak outflow discharge/peak inflow discharge) can be estimated from Figure 2.2.5-1.

Using the following equation from TR-55 for a Type II or Type III rainfall distribution,  $V_s/V_r$  can be calculated.

*Note: Figure 2.2.4-1 can also be used to estimate  $V_s/V_r$ .*

$$V_s/V_r = 0.682 - 1.43 (q_o/q_i) + 1.64 (q_o/q_i)^2 - 0.804 (q_o/q_i)^3 \quad (2.2.9)$$

Where:  $V_s$  = required storage volume (acre-feet)  
 $V_r$  = runoff volume (acre-feet)  
 $q_o$  = peak outflow discharge (cfs)  
 $q_i$  = peak inflow discharge (cfs)

The required storage volume can then be calculated by:

$$V_s = \frac{(V_s/V_r)(Q_d)(A)}{12} \quad (2.2.10)$$

Where:  $V_s$  and  $V_r$  are defined above  
 $Q_d$  = the developed runoff for the design storm (inches)  
 $A$  = total drainage area (acres)

While the TR-55 short-cut method reports to incorporate multiple stage structures, experience has shown that an additional 10-15% storage is required when multiple levels of extended detention are provided inclusive with the 25-year storm.

### 2.2.5.3 Example Problem

Compute the 100-year peak discharge for a 50-acre wooded watershed located in Peachtree City, which will be developed as follows:

- Forest land - good cover (hydrologic soil group B) = 10 ac
- Forest land - good cover (hydrologic soil group C) = 10 ac
- 1/3 Acre residential (hydrologic soil group B) = 20 ac
- Industrial development (hydrological soil group C) = 10 ac

Other data include the following:

- Total impervious area = 18 acres
- % of pond and swamp area = 0

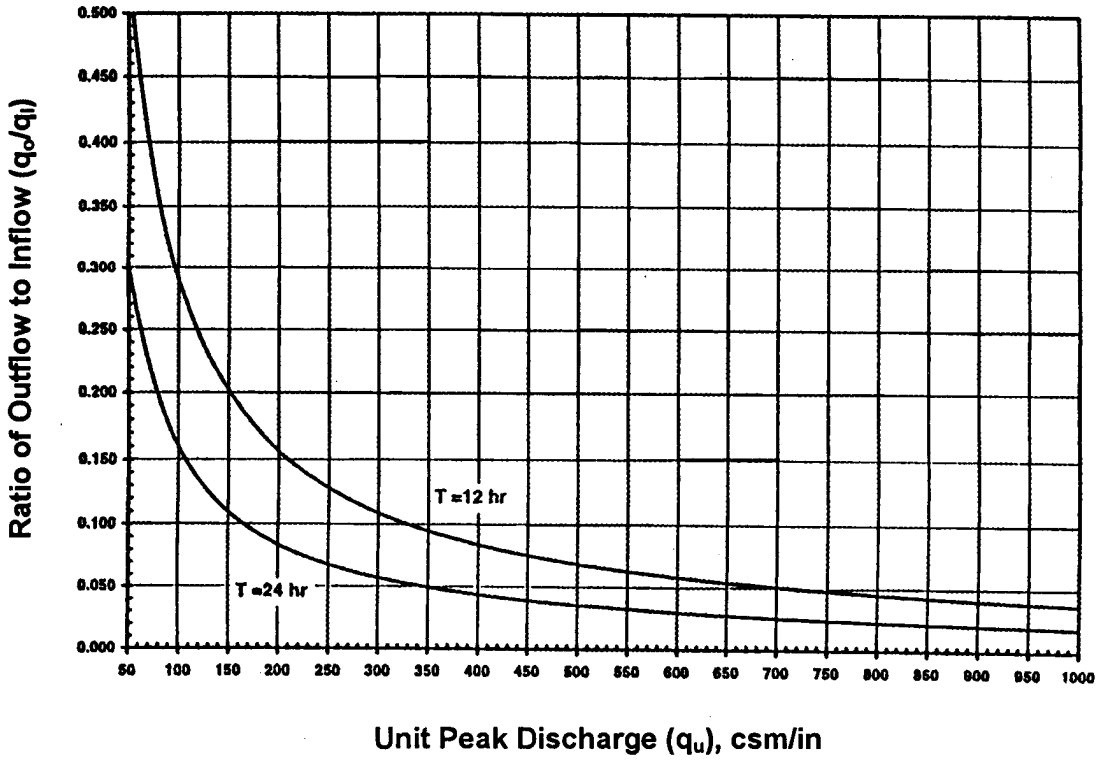

Figure 2.2.5-1 Detention Time vs. Discharge Ratios  
(Source: MDE, 1998)

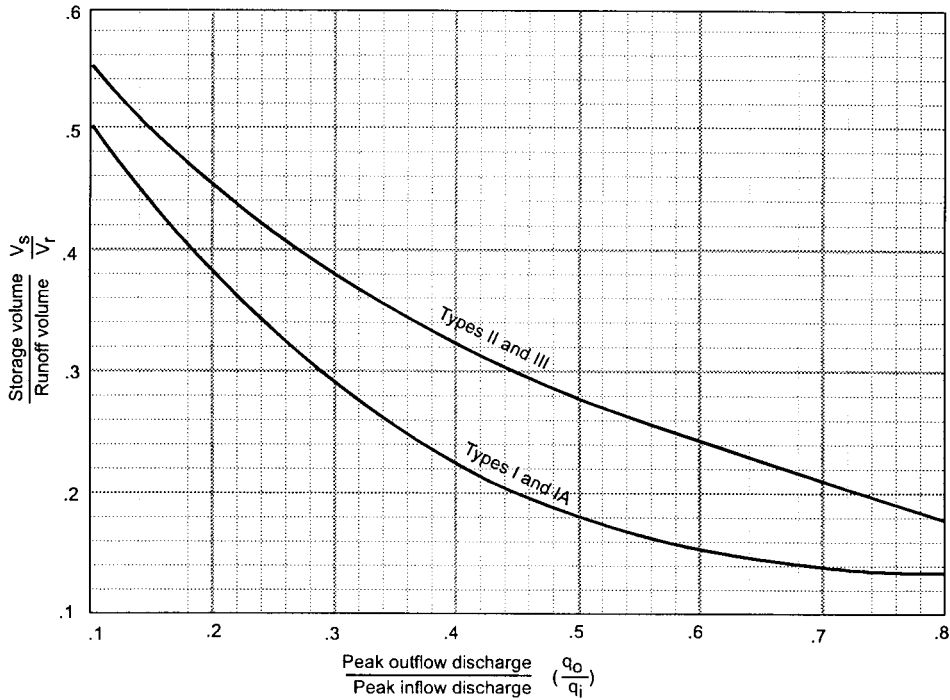

Figure 2.2.5-2  
Approximate Detention Basin Routing for Rainfall Types I, IA, II, and III  
(Source: TR-55, 1986)

---

## Computations

(1) Calculate rainfall excess:

- The 100-year, 24-hour rainfall is 7.92 inches (.33 in/hr x 24 hours – From Appendix A, Table A-10).
- The 1-year, 24 hour rainfall is 3.36 inches (.14 in/hr x 24 hours – From Appendix A, Table A-10).
- Composite weighted runoff coefficient is:

<u>Dev. #</u>	<u>Area (ac)</u>	<u>% Total</u>	<u>CN</u>	<u>Composite CN</u>
1	10	0.20	55	11.0
2	10	0.20	70	14.0
3	20	0.40	72	28.8
4	10	0.20	91	18.2
<hr/>				
Total	50	1.00		72

\* From equation 2.1.6,  $Q$  (100-year) = 4.6 inches  
 $Q_d$  (1-year developed) = 1.0 inches

(2) Calculate time of concentration

The hydrologic flow path for this watershed = 1,890 ft

<u>Segment</u>	<u>Type of Flow</u>	<u>Length (ft)</u>	<u>Slope (%)</u>
1	Overland $n = 0.24$	40	2.0 %
2	Shallow channel	750	1.7 %
3	Main channel*	1100	0.50 %

\* For the main channel,  $n = .06$  (estimated), width = 10 feet, depth = 2 feet, rectangular channel

Segment 1 - Travel time from equation 2.1.9 with  $P_2 = 4.08$  in  
( $0.17 \times 24$  – Appendix A, Table A-10)

$$T_t = [0.42(0.24 \times 40)^{0.8}] / [(4.08)^{0.5} (.020)^{0.4}] = 6.07 \text{ minutes}$$

Segment 2 - Travel time from Figure 2.1.5-5 or equation 2.1.10

$$V = 2.1 \text{ ft/sec (from equation 2.1.10)}$$

$$T_t = 750 / 60 (2.1) = 5.95 \text{ minutes}$$

Segment 3 - Using equation 2.1.12

$$V = (1.49/.06) (1.43)^{0.67} (.005)^{0.5} = 2.23 \text{ ft/sec}$$

$$T_t = 1100 / 60 (2.23) = 8.22 \text{ minutes}$$

$$t_c = 6.07 + 5.95 + 8.22 = 20.24 \text{ minutes (.34 hours)}$$

(3) Calculate  $I_a/P$  for  $C_n = 72$  (Table 2.1.5-1),  $I_a = .778$  (Table 2.1.5-3)

$$I_a/P = (.778 / 7.92) = .098 \text{ (Note: Use } I_a/P = .10 \text{ to facilitate use of Figure 2.1.5-6. Straight line interpolation could also be used.)}$$

(4) Unit discharge  $q_u$  (100-year) from Figure 2.1.5-6 = 650 csm/in,  $q_u$  (1-year) = 580 csm/in

(5) Calculate peak discharge with  $F_p = 1$  using equation 2.1.13

$$Q_{100} = 650 (50/640)(4.6)(1) = 234 \text{ cfs}$$

(6) Calculate water quality volume ( $WQ_v$ )

Compute runoff coefficient,  $R_v$   
 $R_v = 0.50 + (IA)(0.009) = 0.50 + (18)(0.009) = 0.21$

Compute water quality volume,  $WQ_v$   
 $WQ_v = 1.2(R_v)(A)/12 = 1.2(.21)(50)/12 = 1.05$  acre-feet

(7) Calculate channel protection volume ( $CP_v = V_s$ )

Knowing  $q_u$  (1-year) = 580 csm/in from Step 3 and T (extended detention time of 24 hours), find  $q_o/q_i$  from Figure 2.2.5-1.  
 $q_o/q_i = 0.03$

For a Type II rainfall distribution,  
 $V_s/V_r = 0.682 - 1.43 (q_o/q_i) + 1.64 (q_o/q_i)^2 - 0.804 (q_o/q_i)^3$   
 $V_s/V_r = 0.682 - 1.43 (0.03) + 1.64 (0.03)^2 - 0.804 (0.03)^3 = 0.64$

Therefore, stream channel protection volume with  $Q_d$  (1-year developed) = 1.0 inches, from Step 1, is  
 $CP_v = V_s = (V_s/V_r)(Q_d)(A)/12 = (0.64)(1.0)(50)/12 = 2.67$  acre-feet

## 2.2.6 The Modified Rational Method

### 2.2.6.1 Introduction

For drainage areas of less than 5 acres, a modification of the Rational Method can be used for the estimation of storage volumes for detention calculations.

The Modified Rational Method uses the peak flow calculating capability of the Rational Method paired with assumptions about the inflow and outflow hydrographs to compute an approximation of storage volumes for simple detention calculations. There are many variations on the approach. Figure 2.2.6-1 illustrates one application. The rising and falling limbs of the inflow hydrograph have a duration equal to the time of concentration ( $t_c$ ). An allowable target outflow is set ( $Q_a$ ) based on pre-development conditions. The storm duration is  $t_d$ , and is varied until the storage volume (shaded gray area) is maximized. It is normally an iterative process done by hand or on a spreadsheet. Downstream analysis is not possible with this method as only approximate graphical routing takes place.

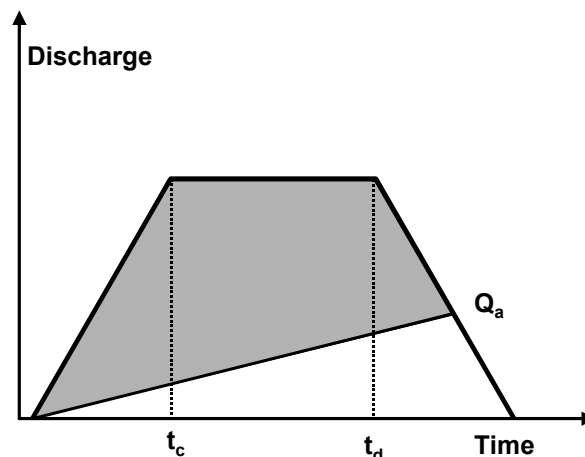

Figure 2.2.6-1 Modified Rational Definitions

---

### 2.2.6.2 Design Equations

The design of detention using the Modified Rational Method is presented as a noniterative approach suitable for spreadsheet calculation (Debo & Reese, 1995).

The allowable release rate can be determined from:

$$Q_a = C_a i A \quad (2.2.11)$$

Where:

- $Q_a$  = allowable release rate (cfs)
- $C_a$  = predevelopment Rational Method runoff coefficient
- $i$  = rainfall intensity for the corresponding time of concentration (in/hr)
- $A$  = area (acres)

The critical duration of storm, the time value to determine rainfall intensity, at which the storage volume is maximized is:

$$T_d = \sqrt{\frac{2CAab}{Q_a}} - b \quad (2.2.12)$$

Where:

- $T_d$  = critical storm duration (min)
- $Q_a$  = allowable release rate (cfs)
- $C$  = developed condition Rational Method runoff coefficient
- $A$  = area (acres)
- $a, b$  = rainfall factors dependent on location and return period taken from Table 2.2.6-1

The required storage volume, in cubic feet can be obtained from equation 2.2.13.

$$V_{\text{preliminary}} = 60 [CAa - (2CabAQ_a)^{1/2} + (Q_a/2)(b-t_c)] \quad (2.2.13a)$$

$$V_{\text{max}} = V_{\text{preliminary}} * P_{180}/P_{td} \quad (2.2.13b)$$

Where:

- $V_{\text{preliminary}}$  = preliminary required storage (ft<sup>3</sup>)
- $V_{\text{max}}$  = required storage (ft<sup>3</sup>)
- $t_c$  = time of concentration for the developed condition (min)
- $P_{180}$  = 3-hour (180-minute) storm depth (in)
- $P_{td}$  = storm depth for the critical duration (in)
- all other variables are as defined above

The equations above include the use of an adjustment factor to the calculated storage volume to account for undersizing. The factor ( $P_{180}/P_{td}$ ) is the ratio of the 3-hour storm depth for the return frequency divided by the rainfall depth for the critical duration calculated in equation 2.2.12.

The Modified Rational Method also often undersizes storage facilities in flat and more sandy areas where the target discharge may be set too large, resulting in an oversized orifice. In these locations a C factor of 0.05 to 0.1 should be used.

### 2.2.6.3 Example Problem

A 5-acre site is to be developed in Atlanta. Based on site and local information, it is determined that channel protection is not required and that limiting the 25-year and 100-year storm is also not required. The local government has determined that the development must detain the 2-year and 10-year storms. Rainfall values are taken from Appendix A. The following key information is obtained:

A = 5 acres  
Slope is about 5%

Pre-development  $t_c = 21$  minutes and C factor = 0.22  
Post-development  $t_c = 10$  minutes and C factor = 0.80

Steps	2 - year	10 - year
$t_c$ (min)	21	21
$i$ (in/hr)	3.34	4.51
$Q_a$ (equation 2.2.11) (cfs)	3.67	4.96
$a$ (from Table 2.2.6-1)	123.19	184.23
$b$ (from Table 2.2.6-1)	15.91	19.96
$V_{max}$ (equation 2.2.13) (ft <sup>3</sup> )	16,017	23,199
$P_{180}$ (from Table A-2) (in)	2.43	3.42
$T_d$ (equation 2.2.12) (min)	49	57
$P_{td}$ (from Table A-2) (in)	1.62	2.70
$V_{max}$ (equation 2.2.13) (ft <sup>3</sup> )	24,025	29,385

**Table 2.2.6-1** Rainfall Factors “a” and “b” for the Modified Rational Method (1-year through 100-year return periods)

City		Return Interval						
		<u>1</u>	<u>2</u>	<u>5</u>	<u>10</u>	<u>25</u>	<u>50</u>	<u>100</u>
<b>Albany</b>	a	126.72	159.17	198.14	230.00	271.84	305.29	341.98
	b	16.02	19.72	22.52	24.49	26.00	26.97	28.23
<b>Atlanta</b>	a	97.05	123.19	157.99	184.23	219.21	249.86	278.71
	b	12.88	15.91	18.44	19.96	21.13	22.28	23.01
<b>Athens</b>	a	106.01	126.29	162.23	187.80	224.41	253.05	281.69
	b	15.41	16.95	19.57	20.87	22.19	22.99	23.68
<b>Augusta</b>	a	119.32	142.78	171.04	192.10	221.48	247.98	271.24
	b	17.05	19.12	20.34	20.96	21.40	22.10	22.32
<b>Bainbridge</b>	a	128.79	171.90	215.02	245.38	291.64	329.59	367.38
	b	16.39	21.13	24.33	25.87	27.73	29.12	30.26
<b>Brunswick</b>	a	177.81	191.06	233.75	266.24	314.79	352.59	367.38
	b	26.30	24.13	27.51	29.49	31.77	33.16	34.22
<b>Columbus</b>	a	113.09	142.00	177.92	205.63	246.52	273.92	306.45
	b	15.67	17.87	20.34	21.88	23.63	24.11	25.13
<b>Macon</b>	a	111.40	139.06	176.78	203.43	242.56	272.93	306.45
	b	15.48	17.68	20.55	21.94	23.47	24.38	25.59
<b>Metro Chattanooga</b>	a	93.15	116.20	148.58	171.22	201.95	227.07	254.06
	b	14.25	15.97	18.00	18.91	19.60	20.12	20.84
<b>Peachtree City</b>	a	101.63	125.43	160.73	185.58	219.86	250.95	277.86
	b	13.72	15.94	18.64	19.91	21.02	22.25	22.81
<b>Rome</b>	a	88.91	120.41	159.75	188.99	229.97	264.15	292.64
	b	12.10	16.05	19.06	20.82	22.51	23.81	24.21
<b>Roswell</b>	a	93.33	126.28	159.12	182.23	219.74	246.68	273.06
	b	12.28	16.92	19.00	19.96	21.54	22.17	22.67

---

**Table 2.2.6-1 (continued)**

<b>Savannah</b>	a	135.97	178.06	230.29	266.68	325.90	373.89	418.97
	b	19.41	23.22	28.28	30.80	34.41	36.82	38.60
<b>Toccoa</b>	a	114.77	124.54	164.15	192.50	234.48	266.57	299.01
	b	19.58	17.40	20.33	21.85	23.67	24.65	25.51
<b>Valdosta</b>	a	132.93	165.35	203.32	229.47	269.41	301.00	333.57
	b	16.72	19.94	22.63	23.79	25.20	26.10	26.98
<b>Vidalia</b>	a	120.40	161.23	201.42	230.71	272.84	310.23	343.58
	b	15.00	20.17	23.69	25.24	26.80	28.32	29.15

---

## References

Debo, Thomas N., and Andrew J. Reese, 1995. Municipal Storm Water Management. Lewis Publishers: CRC Press, Inc., Boca Raton, Florida.

Metropolitan Government of Nashville and Davidson County, 1988. Stormwater Management Manual - Volume 2 Procedures. Prepared by AMEC, Inc. (formerly The Edge Group) and CH2M Hill.

Wycoff, R. L. and U. P. Singh, 1976. Preliminary Hydrologic Design of Small Flood Detention Reservoirs. Water Resources Bulletin. Vol. 12, No. 2, pp 337-49.